



### Bracket Kit For Connecting 2 Seats

- A Screw (8)
- B Hex nut (8)
- C Attachment bracket (4)

Contents

**PLEASE NOTE:** A screwdriver and wrench (not included) are required for installation.

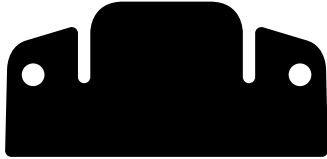
 x 8	 x 8	 x 4
---	---	---



Scan this QR code for  
an instructional video.

**When attaching the brackets to a seat that has  
an attached arm, follow these instructions.**

Figure 1

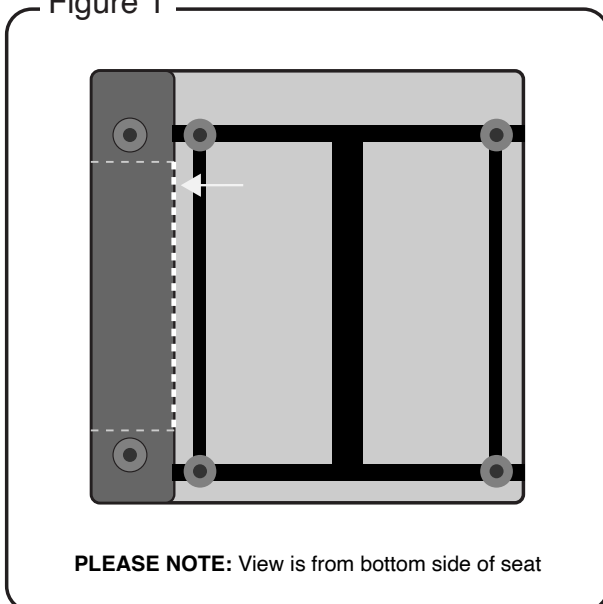

Figure 1

Tip the seat forward exposing the underside of the seat. Find the Velcro strip, then separate it to expose the inside of the seat's attached arm.

Figure 2

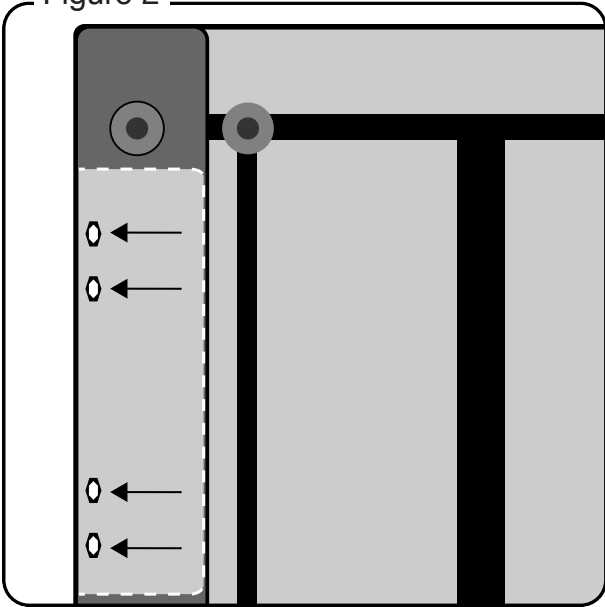

Figure 2

Inside the seat arm locate the 4 pre-drilled screw holes on the outer arm wall. Insert a small sharp object to pierce through the holes from the inside of the seat, penetrating the material on the outside of the seat arm.

Figure 3

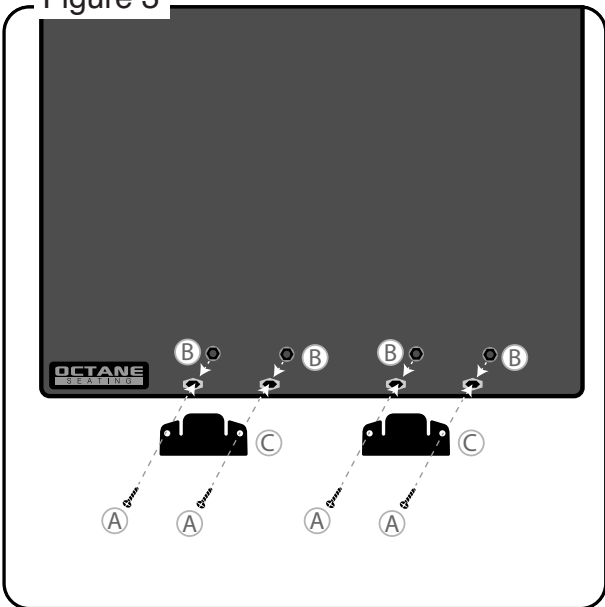

Figure 3

On the outside of the arm align the holes of the attachment bracket (C) with the holes on the arm. Place the screw (A) through the attachment bracket (C), then through the hole in the arm. Attach the hex nut (B) to the screw from the inside of the arm. Use a screwdriver and wrench to hold the nut in place (not included) and tighten the screw.

Repeat these steps with the second bracket.

**NOTE:** When standing in front of the seats looking at them, the brackets on the left side should always face down, and the brackets on the right side should always face up.

## When attaching the brackets to a seat without an attached arm, follow these instructions.

Figure 4

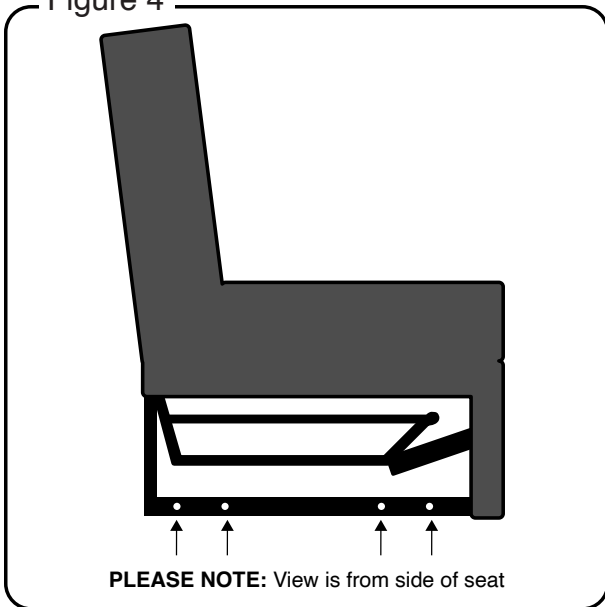

Figure 4

For seat's with no attached arm, locate the 4 pre-drilled holes on the metal brace at the base of the seat frame.

Figure 5

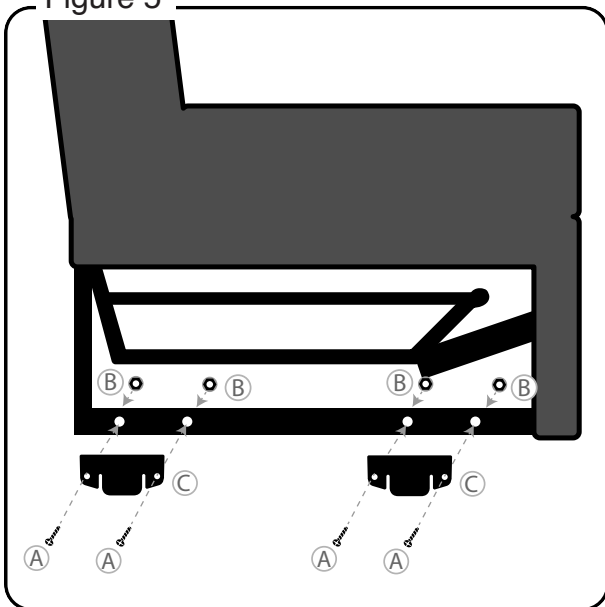

Figure 5

Align the holes of the attachment bracket (C) with the holes on the frame. Place the screw (A) through the attachment bracket (C), then through the hole in the frame. Attach the hex nut (B) to the screw from the inside of the frame. Using a screwdriver and wrench, tighten the nut and screw.

Repeat these steps with the second bracket.

Figure 6

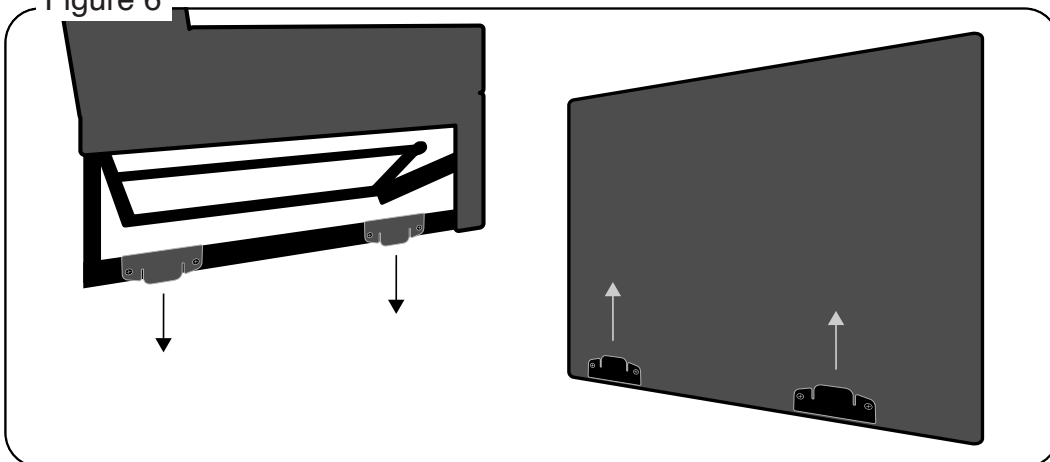

Figure 6

Join the two seats together by placing the downward facing brackets over the top of the upward facing brackets, hooking them together.